



# INSTALLATION INSTRUCTIONS

Accessory  
STEERING WHEEL

Application  
2013 TL

Publications No.  
BII 13394  
Issue Date  
AUG 2012

## PARTS LIST

Steering wheel



2 TORX bolts

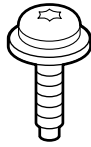

Information

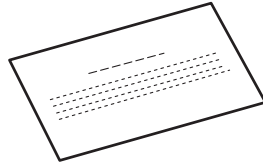

## TOOLS AND SUPPLIES REQUIRED

Phillips screwdriver  
14 mm T-handle wrench  
T30 TORX wrench  
Steering wheel puller  
Service Manual  
Torque wrench  
Plastic Trim Tool (T/N SILTRIMTL10)  
10 mm Wrench

## INSTALLATION

**Client Information:** The information in this installation instruction is intended for use only by skilled technicians who have the proper tools, equipment, and training to correctly and safely add equipment to your vehicle. These procedures should not be attempted by “do-it-yourselfers.”

### NOTE:

- Observe all safety notes and precautions in the service manual in addition to these in this installation instruction.
  - Be extremely careful not to damage any interior panels.
  - After installing the steering wheel, you must align the steering wheel spoke angle to the straight ahead position by adjusting the front toe.
1. Make sure you have the anti-theft codes for the audio and navigation system (if equipped), then write down the audio presets.

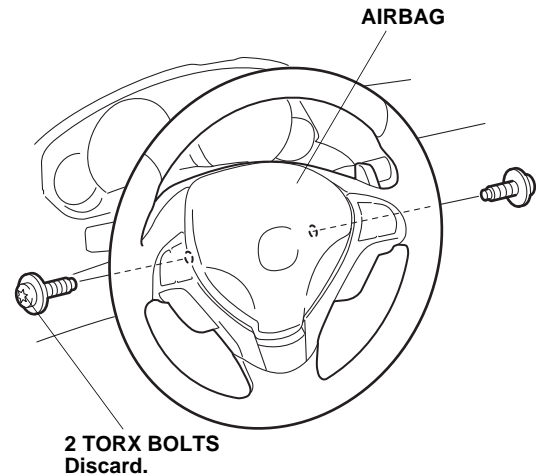

2. Remove and discard the two TORX bolts that secure the airbag.
3. Turn the steering wheel so the front wheels are in the straight-ahead position.

4. Open the hood, and remove the front engine cover (four clips and two hooks).

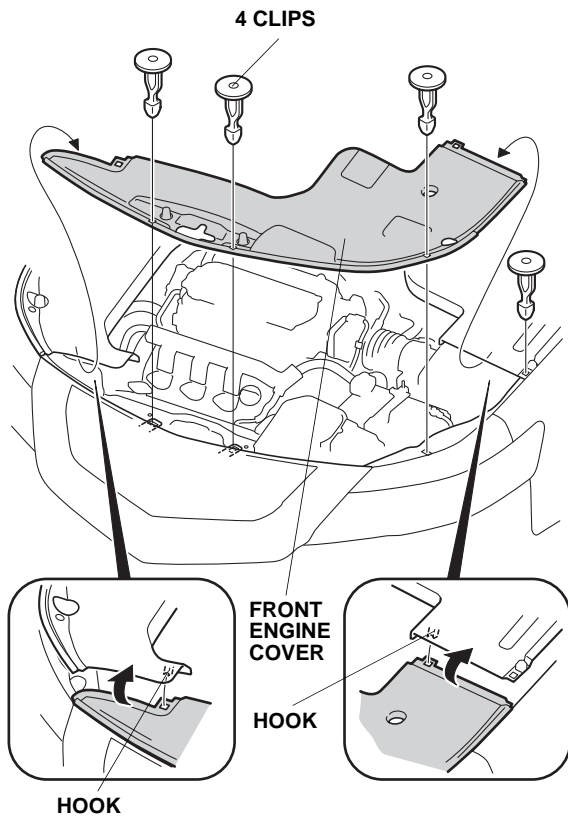

5. Disconnect the negative cable from the battery, and wait at least 3 minutes before you start to install the steering wheel.

6. Remove the access panel from under the driver's side airbag.

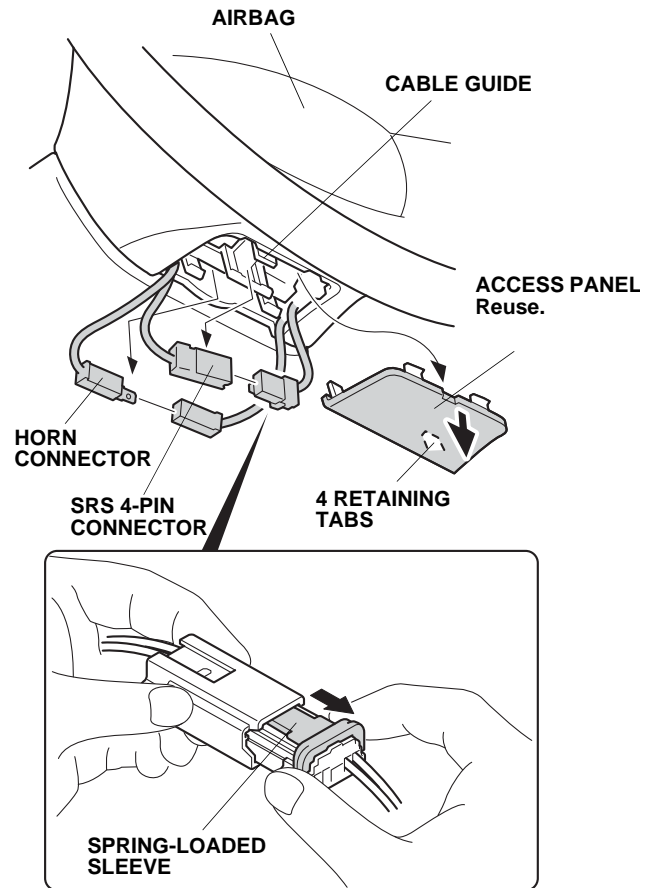

7. Remove the horn connector from the cable guide. Unplug the horn connector.
8. Remove the SRS 4-pin connector from the cable guide.
9. Unplug the SRS 4-pin connector. Pull the spring-loaded sleeve toward the stop while holding the opposite half of the SRS 4-pin connector, then pull the SRS 4-pin connector halves apart. Be sure to pull on the sleeve and not on the harness wires.

10. Remove the airbag (two TORX bolts). Carefully set the airbag in a secure location with the pad facing up. Do not drop or bump the airbag.

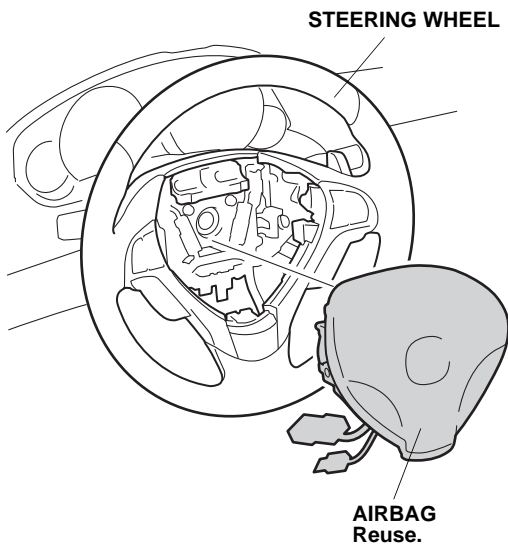

11. Unplug the 20-pin connector from the cable reel. Remove the steering wheel bolt. Using a steering wheel puller, remove the steering wheel. Do not thread the steering wheel puller bolts in more than 10 mm. Be careful not to rotate the steering wheel during removal.

NOTE: Route the SRS 4-pin connector through the steering wheel opening.

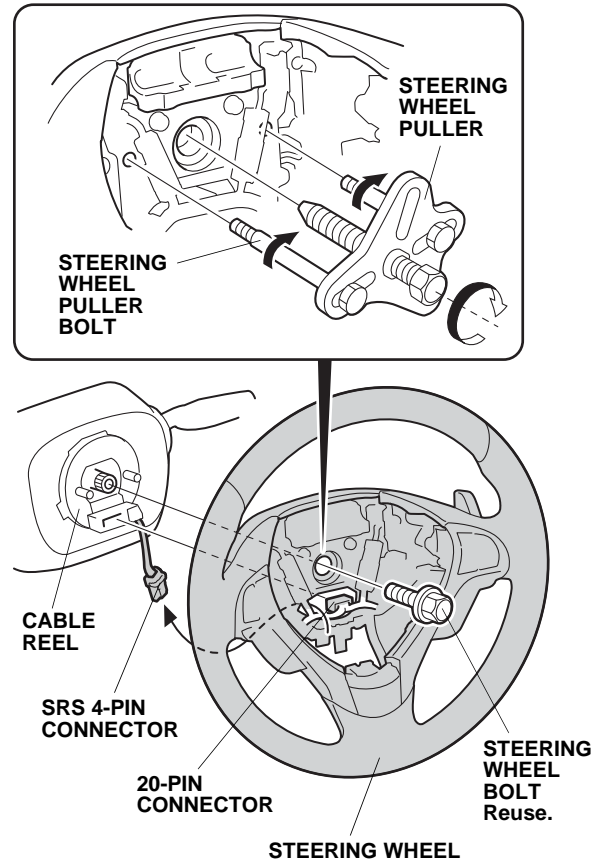

12. Remove the steering wheel cover from the steering wheel (four screws).

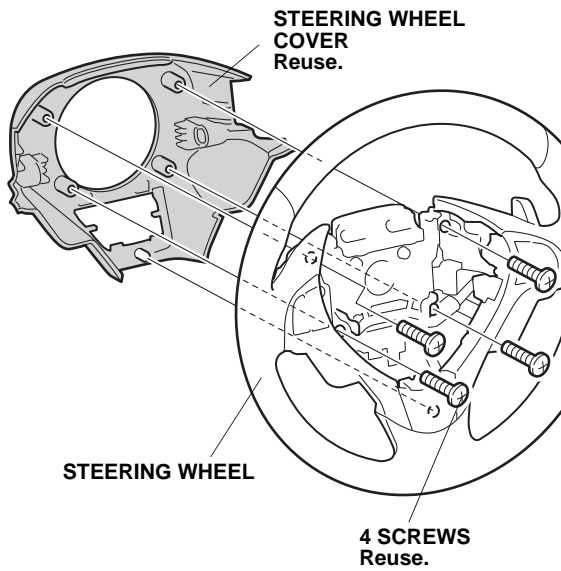

13. Remove the lower cover from the steering wheel (two screws).

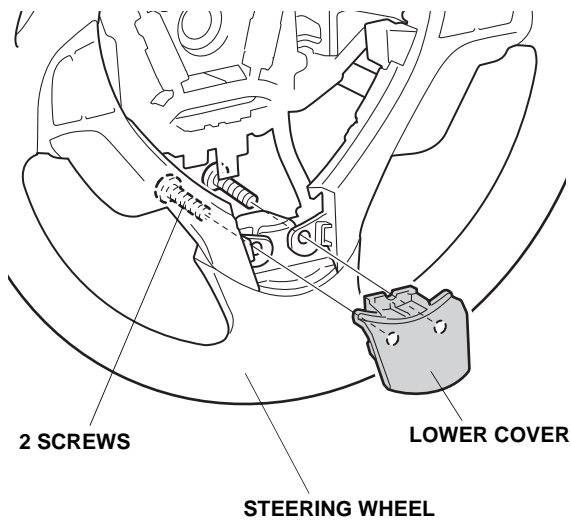

14. Remove the four screws from the left and right paddle switches.

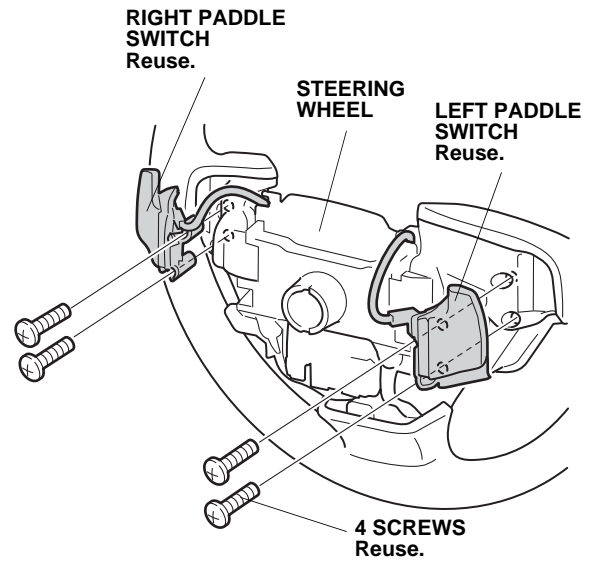

15. Remove the two screws from the audio switch and the cruise switch.

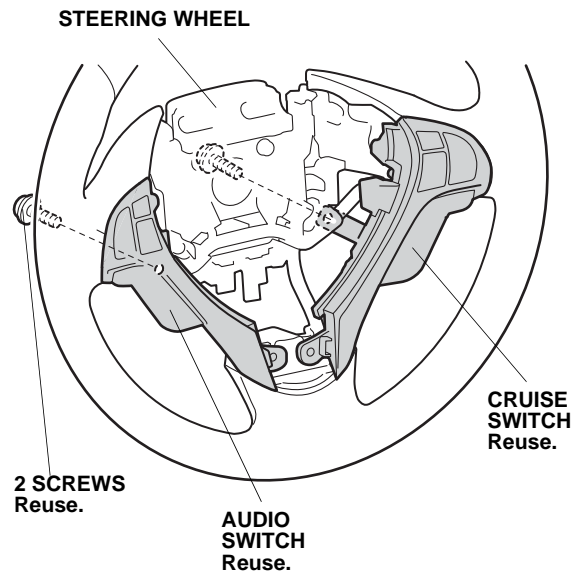

16. If equipped, remove the damper from the steering wheel (two screws).

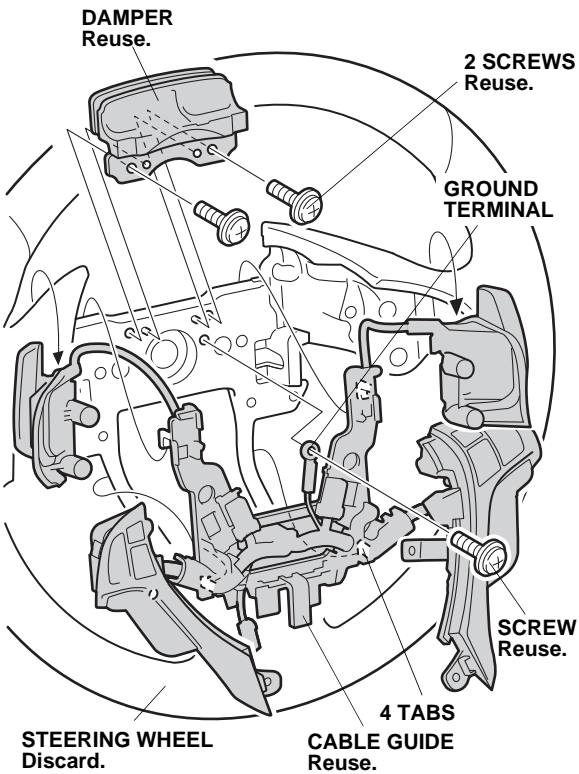

17. Remove the ground terminal from the steering wheel (one screw).
18. Remove the cable guide assembly with both paddle switches, the audio switch, and the cruise switch from the steering wheel (four tabs).

19. Install the cable guide assembly with both paddle switches, the audio switch, and the cruise switch on the new steering wheel.

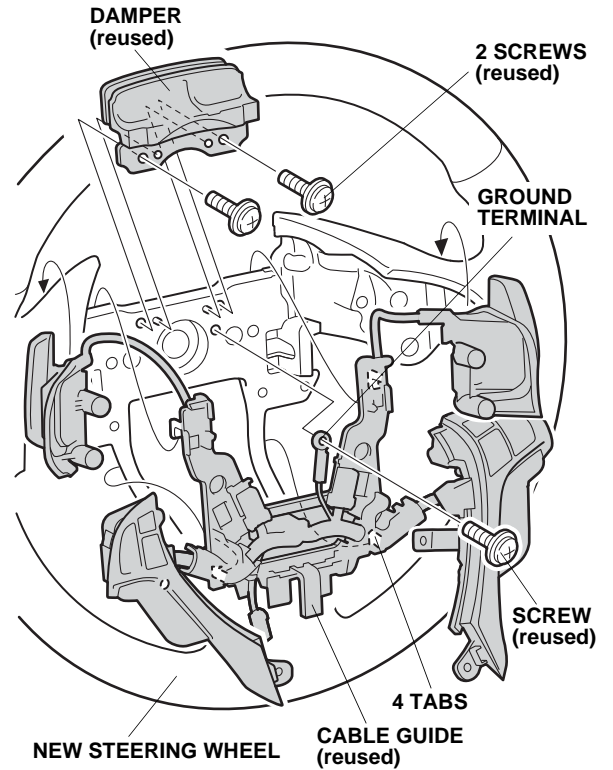

20. Install the ground terminal to the new steering wheel using one screw.
21. If equipped, install the damper to the new steering wheel using the two screws.
22. Install the audio switch and the cruise switch to the new steering wheel using two screws.

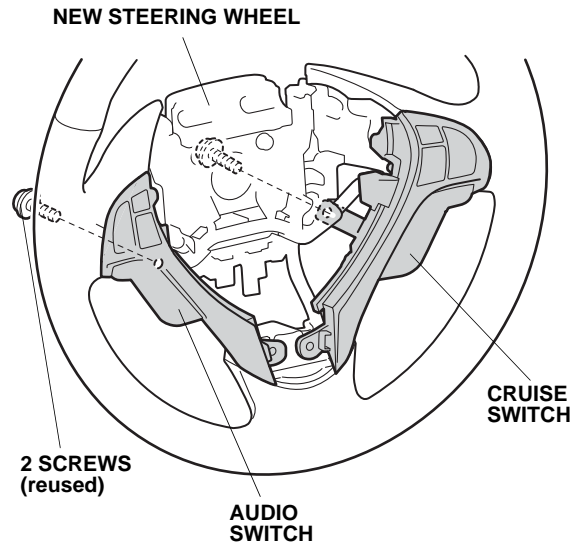

23. Install the left and right paddle switches to the new steering wheel using four screws.

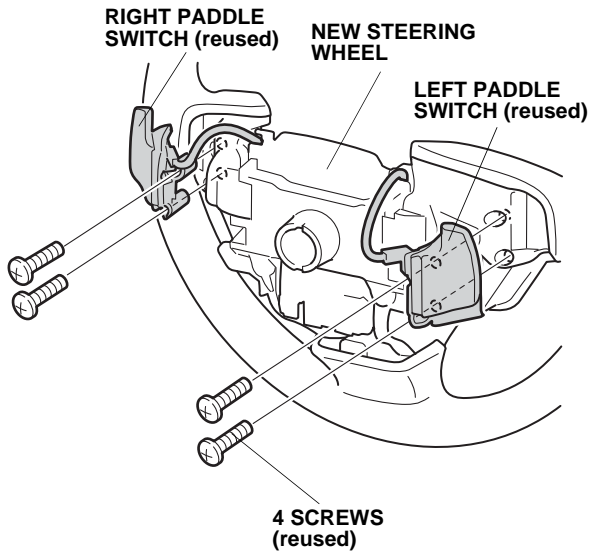

24. Install the lower cover on the new steering wheel using two screws.

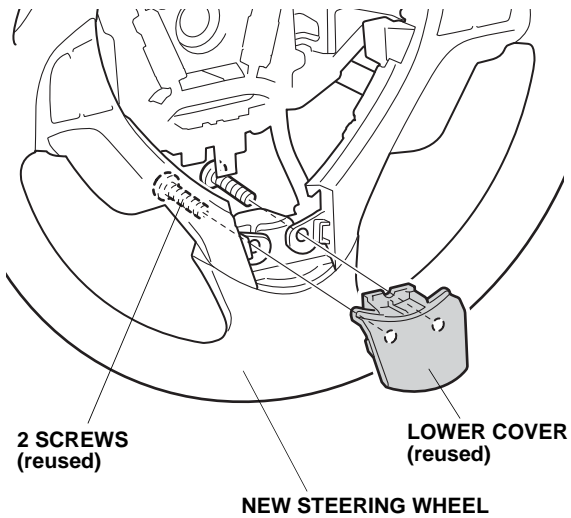

25. Install the steering wheel cover to the new steering wheel using four screws.

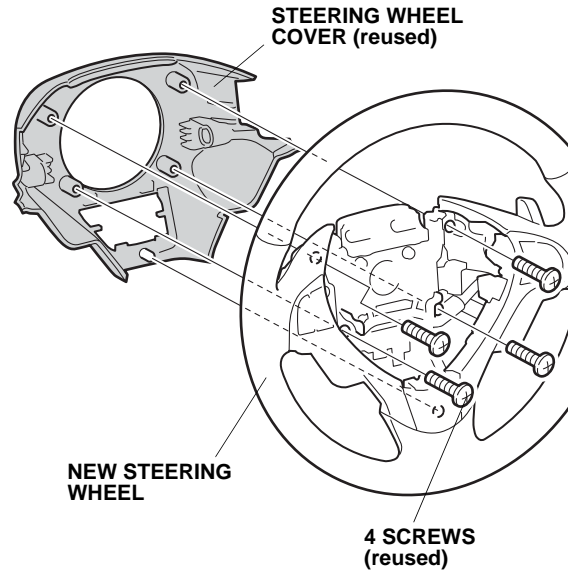

If the cable reel was moved, continue with step 26; if it was not moved, go to step 27.

26. Align the cable reel:

- Rotate the cable reel clockwise all the way until it stops.
- Turn the cable reel counterclockwise about three complete turns until the arrow on the cable reel points up.

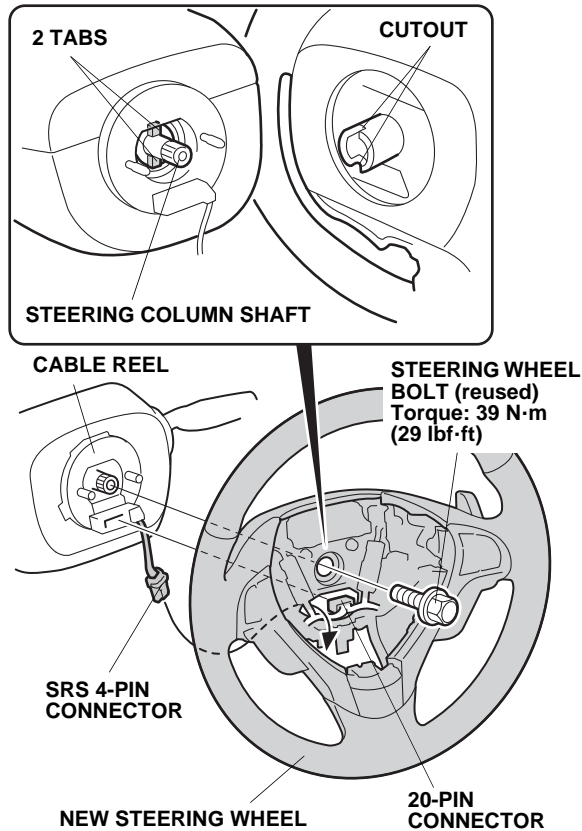

27. Install the new steering wheel on the steering column shaft in the straight-ahead position:

- Route the SRS 4-pin connector through the opening in the new steering wheel.
- Align the two tabs on the canceling sleeve with the two cutouts in the new steering wheel as shown.
- Check that the wire harnesses are not pinched.

28. Install the steering wheel bolt. Torque the steering wheel bolt to 39 N·m (29 lbf·ft).

29. Plug the 20-pin connector into the cable reel.

30. Install the airbag on the new steering wheel.

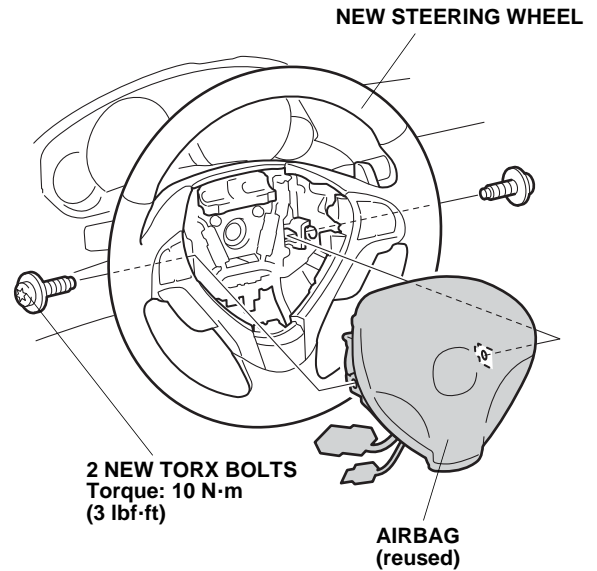

31. Install two new TORX bolts. Torque the TORX bolts to 10 N·m (3 lbf·ft).

32. Plug in the SRS 4-pin connectors:
- Holding the pawl-side of the SRS 4-pin connector, press on the sleeve-side of the SRS 4-pin connector in the direction shown.
  - Do not touch the sleeve, the sleeve is pushed back by the pawl when the two SRS 4-pin connectors mate.
  - Reattach the SRS 4-pin connector to the cable guide.
  - Plug the horn connector and reattach it to the cable guide.
  - Reinstall the access panel.

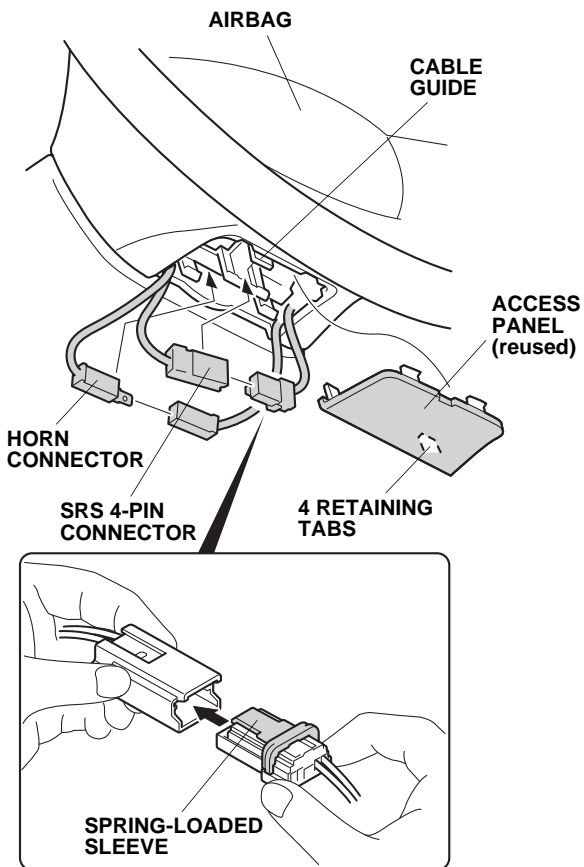

33. Reconnect the negative cable to the battery.
34. Reinstall the front engine cover.
35. Make sure the steering wheel is in the straight-ahead position with the front wheels. If the spoke angle of the steering wheel is not in the straight-ahead position with the front wheels, adjust the front toe as described in the service manual.
36. Make sure that the horn works.
37. Turn the ignition key on, and verify that the SRS warning light comes on and stays on for 6 seconds. Turn the key off to make sure the SRS warning light goes off.
38. Enter the anti-theft code for the audio and the navigation system (if equipped), then enter the audio presets.
39. Reset the clock (without navigation).